

LOW PRESSURE, HIGH FLOW, OIL-FREE

AIR DRIVEN GAS BOOSTERS



FOR USE WITH:

- Liquefied gases at ambient temperature (both phases)
- Vaporizers off cryogenic tanks
- Instrument air (or plant air)

MODEL SELECTION – BASIC DATA

ITEM	MODEL	SCHEMATIC SYMBOL	TYPICAL APPLICATION	ACTUAL DISPL. IN ³ PER CYCLE	PUMPING ACTION	APPROXIMATE LENGTH, HEIGHT, WIDTH, WEIGHT
1	7G-DS-7 (7" Drive)		Boosting Argon, Nitrogen, Oxygen, Hydrogen, Methane, instrument air or similar gases from 100 - 400 PSI sources up to 700 - 1100 PSI output at flows to 60 SCFM, oil free.	41.4	Single Stage, Double Acting	25" x 11" x 9" 57 lbs.
2	7G-TS-7 (7" Drive)		Boosting pure gases from low pressure sources down to moderate vacuum while providing 400 - 700 PSI gas output, oil free.	21.6	Two Stage	25" x 11" x 9" 57 lbs.
3	7A-DS-8 (7" Drive)		Driven by and boosting 60 - 100 PSI plant compressed air into 200 - 600 PSI receivers to back up air powered production machines or tools.	41.4	Single Stage, Double Acting	18" x 11" x 9" 50 lbs.
4	7LG-TS-7 (7" Drive)		Transferring and extracting valuable liquefied gases such as SF6, LPG Halon, Freon from their liquid phase on down to the vapor phase with moderate vacuum at inlet, while delivering up to 700 PSI output with item 4; 400 PSI with item 5.	21.6	Two Stage	18" x 11" x 15" 50 lbs.
5	5LG-TS-4 (5 1/4" Drive)			12.0		14" x 9.5" x 9.4" 30 lbs.

Providing High Pressure Solutions with Air Driven Liquid Pumps & Gas Boosters



HYDRAULICS INTERNATIONAL, INC.

9201 Independence Ave., Chatsworth, CA 91311, USA

Tel: (818) 407-3400 (888) 780-7867 Fax: (818) 407-3428 E-Mail: sales@hiipumps.com www.hiipumps.com

PRINCIPLES OF OPERATION

The basic unit consists of a large area double acting drive piston directly connected, through a high pressure seal and bearings, to a double acting boost piston. The drive section includes a spool type directional control valve and 2 poppet type pilot valves so that it will automatically reciprocate whenever compressed air (or a suitable gas) is applied to the drive port. Drive exhaust is routed to a muffler which is positioned near the finned gas section to enhance cooling.

In the double acting (DS) models, the boost piston provides double acting output flow due to the action of the dual inlet and outlet check valves built in.

In the two stage (TS) models, output is only provided during the "pull" stroke (2nd stage). On the opposite stroke (1st stage), gas is compressed and transferred into the 2nd stage whose volume is somewhat smaller due to the connecting rod.

All models are also "lift pumps" in that the inlet pressure acts directly on the boost piston area so that the ultimate pressure lift potential is:

Items 1, 2, 3, 4	Drive pressure x 7:1 area ratio + inlet pressure
Item 5	Drive pressure x 4:1 area ratio + inlet pressure

The maximum pressure ratings for all models are:

150 PSI drive section 1250 PSI boost section

Note: The TS models also can excessively intensify output pressure well beyond the 1250 PSI maximum due to a balance of areas, if allowed to stall. When boosting gas, this is rarely encountered due to gas compressibility and the provision of gas relief valves in the system. Models 7LG-TS-7 or 5LG-TS-4 however, may be boosting incompressible liquid. Therefore a safety relief valve at the outlet, set at approximately 900 PSI, is included.

ASSEMBLY VIEWS

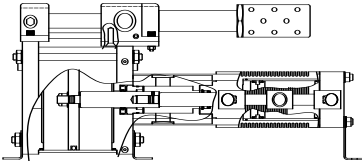

Models 7G-DS-7
7G-TS-7

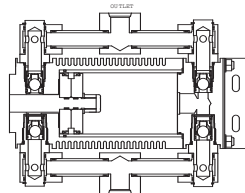

-DS BOOST SECTION

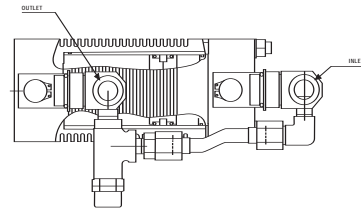

-LG-TS BOOSTER SECTION

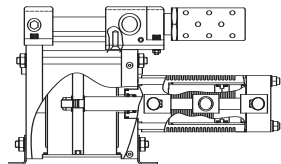

Models 7A-DS-7
7LG-TS-7

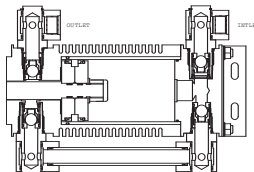

-TS BOOST SECTION

PORTING					
GAS SECTION			DRIVE SECTION		
ITEM	INLET	OUTLET	ITEM	INLET	EXHAUST
1,3	-10 SAE	-10 SAE	1,2,3,4	3/4 NPT	1 1/4 NPT
2,4,5	-8 SAE	-8 SAE	5	-8 SAE	1/2 NPT

Gas section materials: Aluminum, stainless steel, PTFE, Viton
(other o ring compounds optional)

PERFORMANCE

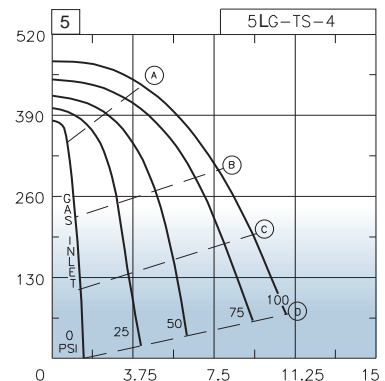
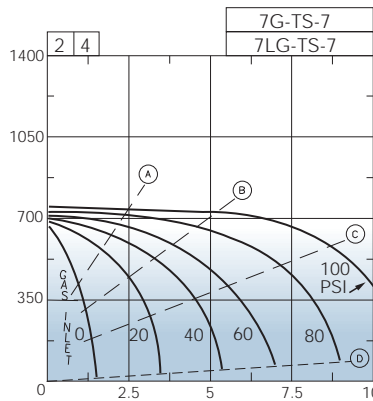
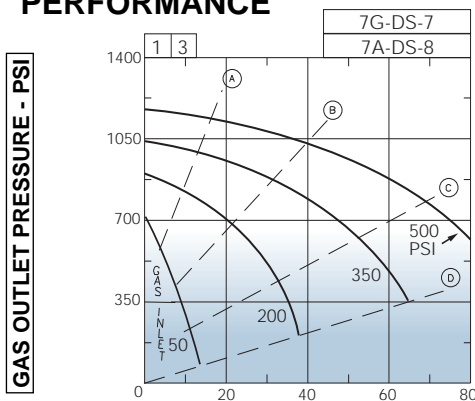

GAS OUTLET FLOW-SCFM

Drive pressure: 95 PSI.

Approximate air drive

Consumption lines: Items 1, 2, 3, 4 (A) 45 SCFM (B) 85 SCFM (C) 120 SCFM (D) 165 SCFM
Item 5 (A) 15 SCFM (B) 30 SCFM (C) 50 SCFM (D) 75 SCFM

LG-TS Models (ITEMS 4,5)

When used to pump liquified gas, reduce the speed of the drive to 30-35 cycles/min. to maintain a reasonable volumetric efficiency, Approximate Maximum output flow will then be:

For item 4, 2.7 GPM up to 500 psi

For item 5, 1.5 GPM up to 300 psi

This will also vary with ambient temp. and vapor pressure.

